

# MotorGuide REPAIR PARTS

Models: 

## GWB67V

## GWT62V

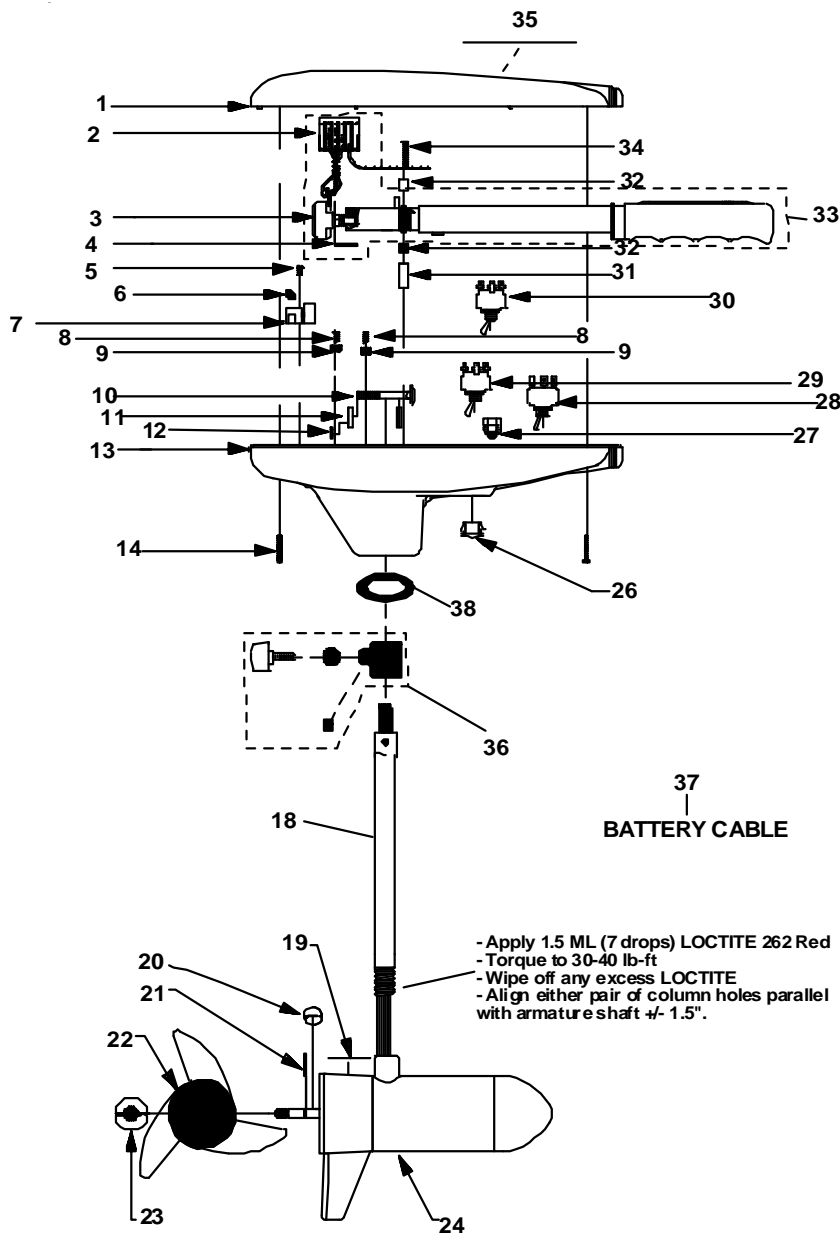

**SPECIFICATIONS:**

Year of Intro	1998
Thrust	67LBS
Volts	24VDC
Amp Draw	0 to 33 amps
Mount	20 Bow
	09 Transom
Speeds	Variable

**QUICK REFERENCE PARTS GUIDE:**

Voltage Switch	TM153-02
DA Board	JF157-02
MOSFET	JF096-08
Motor Seal Kit	6220

**PARTS ORDERING & TECH ASSISTANCE**

MotorGuide Consumer Relations  
 Phone 918-831-6989  
 Fax 800-982-8093

**Send Returned Goods to:**

MotorGuide  
 605 Hwy 12 West  
 Starkville, MS 39760

*Returned Goods must be accompanied with a Returned Goods Authorization. Contact MotorGuide Consumer Relations to obtain RGA.*

KEY	DESCRIPTION	PART #	KEY	DESCRIPTION	PART #
1	TOP HOUSING COVER	XT053-35	24	H/O MOTOR	UF397-03
2	AMP CONNECTOR	AP029-01	25	DEPTH ADJUSTMENT COLLAR	AR051-02
3	POTENTIOMETER	AP168-02	26	HOLE PLUG	FP021-03
4	POT BRACKET	AT155-03	27	GROMMET	GR019-03
5	SELF TAPPING SCREW	XT141-01	28	TOGGLE SWITCH 3 POSITIONS	XT153-02
6	INSULATING SLEEVE	AT080-01	29		
7	DURA AMP BOARD	JF157-02	30	TOGGLE SWITCH 2 POSITIONS	TM153-02
8	#10 X 1/2" SCREW	RT133-01	31	WIRE BRACKET	AT155-04
9	TERMINAL BLOCK	FT160-03	32	RETAINER CLAMP	AR036-01
10	BOLT	TT134-02	33	HANDLE ASY	AT372-03
11	CURVED WASHER	TT171-08	34	8 X 1-3/8 SCREW	AR133-01
12	NYLON LOCK NUT	XT098-01	35	NOMENCLATURE GWB67	XT056-33
13	T/H BASE	AR004-13		NOMENCLATURE GWT62	XT056-25
14	SCREW #8 X 1"	XF141-04	36	DEPTH COLLAR ASY	XT158-01
15	BAR KNOB DEPTH ADJUSTMENT	RT082-02	37	BATTERY CABLE	XT328-01
16	COLUMN CLAMP WASHER	RT171-02			
17	COLUMN SUPPORT NUT	AR098-01			
18	COLUMN 36"	FR049-11			
	COLUMN 42"	FR049-15			
	COLUMN 50"	FR049-13			
19	LOWER UNIT DECAL	XT060-04			
20	MONOFILAMENT WASHER	AR175-01			
21	PROP DRIVE PIN	BR102-01			
22	PROP/2 BLADE (GWB67V)	AF124-07			
	PROP 3 BLADE (BWT62V)	AF124-10			
23	PROP NUT	AR099-01			

LOWER UNIT BREAKDOWN

Models:  
**GWB67V**  
**GWT62V**

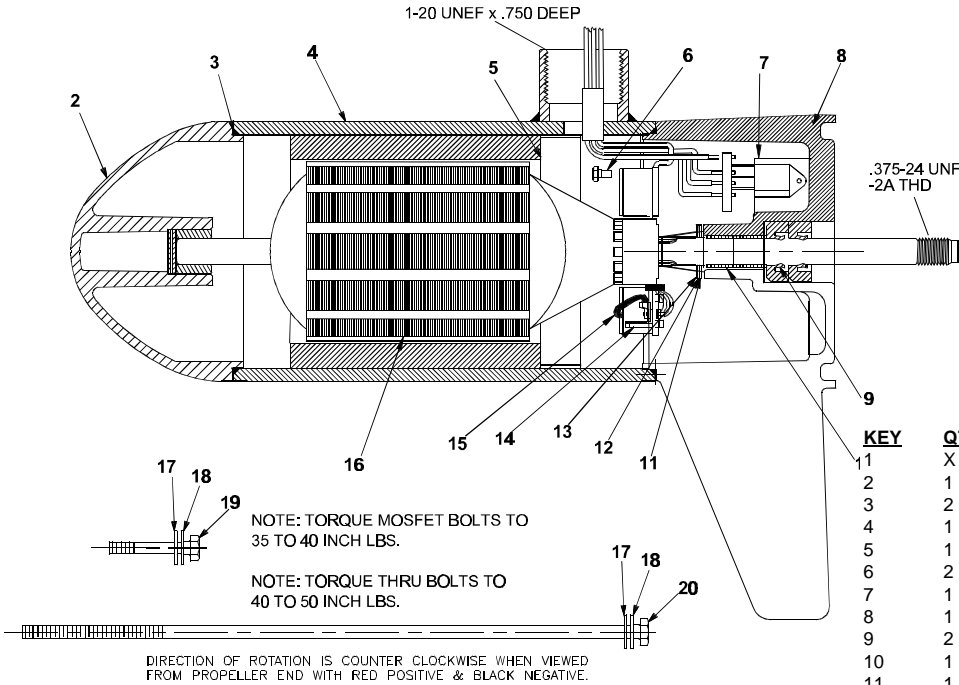

KEY	QTY	DESCRIPTION	PART NO.
1	X	MOTOR	UF397-03
2	1	NOSE CAP	JF3212-02
3	2	O RING SEAL	MR217-01
4	1	HOUSING ASY	UF3210-02
5	1	RETAINER	JF233-01
6	2	BRUSH CARD SCREW	MR228-01
7	1	DURA AMP MODULE	JF096-08
8	1	COMM CAP	UF3205-02
9	2	SHAFT SEAL	MR223-01
10	1	BEARING	MR206-01
11	1	NYLATRON WASHER	MR226-01
12	1	WASHER	MR227-01
13	1	E RING	MR219-01
14	2	BRUSH SPRINGS	MR214-02
15	1	BRUSH ASY LESS SPRING	JF3201-05
16	1	ARMATURE 3.5"	UF3207-01
17	4	STATIC SEAL	MR222-01
18	4	THRU BOLT WASHER	MR216-02
19	2	DURA AMP SCREW	MR229-02
20	2	THRU BOLT	MR218-03

WIRING

